



L P Gas Grill Use and Care

For Outdoor Use Only

QUICKSET[®]

PERFORMANCE
S E R I E S [™]

QUICKSET[®]
TRADITIONAL

ADVANTAGE
S E R I E S

TRADITIONAL[™]

TRADITIONS
S E R I E S
Char-Broil

To installer or person assembling grill: Leave this manual with grill for future reference.

To consumer: Keep this manual for future reference.

This manual applies to a variety of grill styles. Your grill will not have all of the features shown.



WARNING



Read this manual before cooking on grill. Failure to follow all manufacturers' instructions could result in serious personal injury and/or property damage.

Combustion by-products produced when using this product contain chemicals known to the State of California to cause cancer, birth defects, or other reproductive harm.



WARNING



FOR YOUR SAFETY

1. Do not store or use gasoline or other flammable vapors and liquids in the vicinity of this or any other appliance.
2. An LP tank not connected for use shall not be stored in the vicinity of this or any other appliance.

FOR YOUR SAFETY

If you smell gas:

1. Shut off gas to the appliance.
2. Extinguish any open flame.
3. Open lid.
4. If odor continues, immediately call your gas supplier or your fire department.



CAUTION



For residential use only. Do not use for commercial cooking.

Installation Safety Precautions

- Use grill only with LP (propane) gas and the regulator/valve assembly supplied.
- Grill installation must conform with local codes, or in their absence with **National Fuel Gas Code, NFPA 54 / ANSI Z223.1** or **CAN/CGA-B149.2 Propane Installation Code**. Handling and storage of LP cylinders must conform to LP Gas Code **NFPA/ANSI 58**. Grill is not for use in or on recreational vehicles and/or boats.
- All electrical accessories (such as rotisserie) must be electrically grounded in accordance with local codes, or **National Electrical Code, ANSI / NFPA 70** or **Canadian Electrical Code, CSA C22.1**. Keep any electrical cords and/or fuel supply hoses away from any hot surfaces.
- This grill is safety certified for outdoor use in the United States and/or Canada only. Do not modify for use in any other location. Modification will result in a safety hazard.

Call Grill Service Center For Help And Parts

- If you need help or warranty parts please call **1-800-241-7548**.
- **Business hours:**
Open 24 hours - Seven days a week
- To order non-warranty replacement parts or accessories (grill cover, cleaners, paint) call 1-800-993-2677 or send a FAX to 1-706-565-2121.
- Visit us on the web at: www.charbroil.com

Attach receipt here:

Important:

Fill out Warranty information below

Warranty Information

Model Number _____

Serial Number _____

See rating label on grill for serial number.

Date Purchased _____



WARNING



CARBON MONOXIDE HAZARD

Burning charcoal releases carbon monoxide, which has no odor and can cause serious injury or death. Never burn charcoal inside homes, vehicles or tents.

To insure your satisfaction and for follow-up service, register your grill online at:
www.grillregistration.com

Table of Contents

For Your Safety	2
Call Grill Service Center For Help and Parts	2
Fill Out Warranty Information	2
Installation Safety Precautions	2
Table of Contents	3
Safety Symbols	4
Warranty's	4
LP Tank Removal, Transport and Storage	5
LP Tank	5
LP (Liquefied Petroleum Gas)	6
LP Tank Filling	6
LP Tank Exchange	6
LP Tank Leak Test	6
Connecting Regulator To The LP Tank	6, 7
Safety Tips	7
Leak Testing Valves, Hoses and Regulator	8
Valve Check	8
Hose Check	8
Turning Grill Off	8
Ignitor Check	8
For Safe Use Of Your Grill and To Avoid Serious Injury	9
Ignitor Lighting and Match Lighting Traditional Series, QuickSet and QuickSet Traditional	9
Ignitor Lighting and Match Lighting Performance and Advantage Series	10
Sideburner Use	10
Rotisserie Burner Ignitor and Match Lighting	11
Sideburner Ignitor and Match Lighting	11
Burner Flame Check	11
Before Your First Cookout	11
Cleaning The Traditional Series, QuickSet and QuickSet Traditional Burner Assembly	12, 13
Cleaning The Performance and Advantage Burner Assembly	14, 15
Cleaning The Rotisserie Burner	16
Rotisserie Burner Use, Cooking Chart and Cooking Tips	17
General Grill Cleaning	18
Care And Cleaning Of Stainless Steel	19
Natural Hazard Spiders	20
Charcoal/Gas Grills	21
Cooking Chart	22
Food Safety	23
How To Tell If Meat Is Grilled Thoroughly	23
Storing Your Grill	23
Troubleshooting	24, 25
Troubleshooting - Electronic Ignition	26
Recipes by Chef Christopher Koetke, CEC, CCE	27
Recipes	28
www.grillregistration.com	30

Safety Symbols

The symbols and boxes shown below explain what each heading means. Read and follow all of the messages found throughout the manual.

	DANGER	
<p>DANGER: Indicates an imminently hazardous situation which, if not avoided, will result in death or serious injury.</p>		

	WARNING	
<p>WARNING: Indicates a potentially hazardous situation which, if not avoided, could result in death or serious injury.</p>		

	CAUTION	
<p>CAUTION: Indicates a potentially hazardous situation or unsafe practice which, if not avoided, may result in minor or moderate injury.</p>		

Warranty

Manufacturer warrants to the original consumer-purchaser only that this product shall be free from defects in workmanship and materials after correct assembly and under normal and reasonable home use for the periods indicated below beginning with the date of purchase.

Castings - Limited Lifetime

All Burner - 3 years

Electronic ignition (excluding battery) - 3 years

Remaining parts (excluding battery) - 1 year

This limited warranty is for replacement of defective parts only. Manufacturer will not be responsible for failure or damage resulting from use, accident, alteration, misuse, transportation, commercial use, abuse, hostile environments, improper installation or installation not in accordance with local codes.

Manufacturer will, at its option, refinish or replace any product or part found to be defective during its respective warranty period. Manufacturer will require return of the part(s) claimed to be defective, for its inspection, freight or postage prepaid. Manufacturer may require reasonable proof of purchase and suggests that receipts be retained.

This limited warranty does not cover scratches, dents, corrosion or discoloring by heat, abrasive and chemical cleaners or any tools used in the assembly or installation of the appliance. This limited warranty does not cover surface rust, or the discoloration of stainless steel surfaces. This limited warranty does not include the cost of any inconvenience, personal injury or property damage due to failure of the product.

THIS EXPRESS WARRANTY IS THE SOLE WARRANTY GIVEN BY THE MANUFACTURER AND IS IN LIEU OF ALL OTHER WARRANTIES, EXPRESS OR IMPLIED, INCLUDING IMPLIED WARRANTY OF MERCHANTABILITY OR FITNESS FOR A PARTICULAR PURPOSE OR USE.

Neither dealers nor the retail establishment selling this product has any authority to make any additional warranties or to promise remedies in addition to or inconsistent with those stated above. Manufacturer's maximum liability, in any event, shall not exceed the purchase price of the product paid by the original consumer-purchaser.

NOTE: Some states do not allow an exclusion or limitation of incidental or consequential damages, so the above limitations or exclusions may not apply to you. This limited warranty gives you specific legal rights as set forth herein. You may also have other rights which vary from state to state. In the state of California only, if refinishing or replacement of the product is not commercially practicable, the retailer selling this product or the Manufacturer will refund the purchase price paid for the product, less the amount directly attributable to use by the original consumer-purchaser prior to discovery of the nonconformity. In addition, in the state of California only, you may take the product to the retail establishment selling this product in order to obtain performance under this limited warranty.

If you wish to obtain performance of any obligation under this limited warranty, you should write to:

Consumer Warranty / P.O. Box 1240

Columbus, GA 31902-1240



DANGER



- Never fill the cylinder beyond 80% full. An overfilled LP tank is hazardous due to possible gas released from the safety relief valve.
- The safety relief valve on the LP tank could activate releasing gas and cause an intense fire with risk of property damage, serious injury or death.
- NEVER store a spare LP tank under or near grill or in enclosed areas.

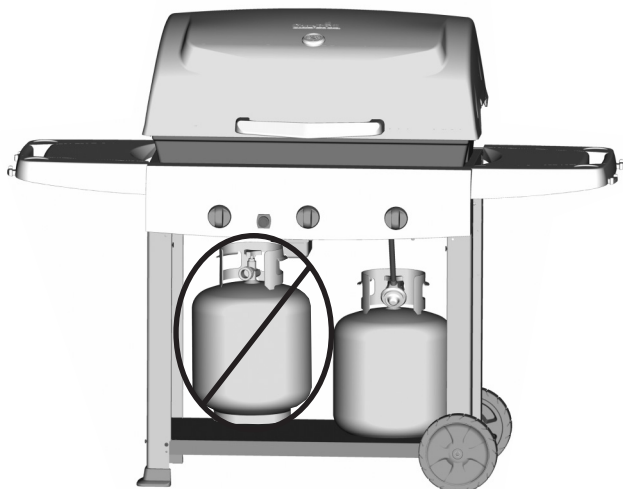

- If you see, smell or hear escaping gas, immediately get away from the LP tank/grill and call your fire department.
- All spare LP tanks must have safety caps installed on the LP tank outlet.

LP Tank Removal, Transport And Storage

- Turn OFF all control knobs and LP tank valve. Turn coupling nut counterclockwise by hand only - do not use tools to disconnect. Remove attachment holding LP tank, then lift up and off support bracket. Install safety cap onto LP tank valve. Always use cap and strap supplied with valve. **Failure to use safety cap as directed may result in serious personal injury and/or property damage.**

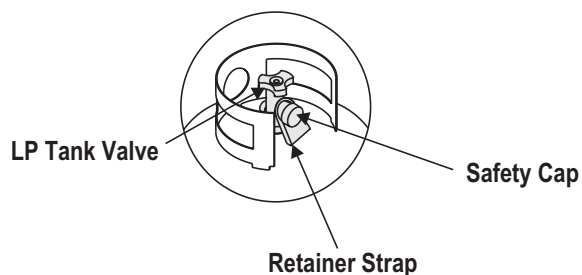

- A disconnected LP tank in storage or being transported must have a safety cap installed (as shown). Do not store an LP tank in enclosed spaces such as a carport, garage, porch, covered patio or other building. Never leave an LP tank inside a vehicle which may become overheated by the sun. Always keep LP tank in upright position during use, transit or storage.
- Do not store an LP tank in an area where children play.

LP Tank

- **The LP tank used with your grill must meet the following requirements:**
 - Use LP tanks only with these required measurements: 12" (30.5cm) (diameter) x 18" (45.7 cm) (tall) with 20 lb. (9 kg.) capacity maximum.
 - LP tanks must be constructed and marked in accordance with specifications for LP tank of the U.S. Department of Transportation (DOT) or for Canada, CAN/CSA-B339, cylinders, spheres and tubes for transportation of dangerous goods. Transport Canada (TC). See LP tank collar for marking.
- LP tank valve must have:
 - Type 1 outlet compatible with regulator or grill.
 - Safety relief valve.
 - UL listed Overfill Protection Device (OPD). This OPD safety feature is identified by a unique triangular hand wheel. **Use only LP tanks equipped with this type of valve.**
- LP tank must be arranged for vapor withdrawal and include collar to protect LP tank valve.



LP (Liquefied Petroleum Gas)

- LP gas is nontoxic, odorless and colorless when produced. **For Your Safety**, LP gas has been given an odor (similar to rotten cabbage) so that it can be smelled.
- LP gas is highly flammable and may ignite unexpectedly when mixed with air.

LP Tank Filling

- Use only licensed and experienced dealers.
- LP dealer must purge a new tank before filling.
- Dealer should NEVER fill LP tank more than 80% of LP tank volume. Volume of propane in tank will vary by temperature.
- A frosty regulator indicates gas overfill. Immediately close LP tank valve and call local LP gas dealer for assistance.
- Do not release liquid propane (LP) gas into the atmosphere. This is a hazardous practice.
- To remove gas from LP tank, contact an LP dealer or call a local fire department for assistance. Check the telephone directory under "Gas Companies" for nearest certified LP dealers.

LP Tank Exchange

- Many retailers that sell grills offer you the option of replacing your empty LP tank through an exchange service. Use only those reputable exchange companies that inspect, precision fill, test and certify their cylinders. **Exchange your tank only for an OPD safety feature-equipped tank as described in the "LP Tank" section of this manual.**
- Always keep new and exchanged LP tanks in upright position during use, transit or storage.
- **Leak test new and exchanged LP tanks BEFORE connecting to grill.**

LP Tank Leak Test

For your safety

- Leak test must be repeated each time LP tank is exchanged or refilled.
- Do not smoke during leak test.
- Do not use an open flame to check for gas leaks.
- Grill must be leak tested outdoors in a well-ventilated area, away from ignition sources such as gas fired or electrical appliances. During leak test, keep grill away from open flames or sparks.

- Use a clean paint brush and a 50/50 soap and water solution. **Use mild soap and water. ▲ Do not use household cleaning agents.** Damage to gas train components can result.

Brush soapy solution onto areas indicated by arrows.

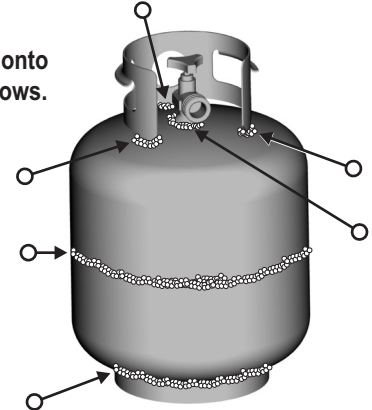

	WARNING	
If "growing" bubbles appear do not use or move the LP tank. Contact an LP gas supplier or your fire department!		

Connecting Regulator To The LP Tank

1. LP tank must be properly secured onto grill. (Refer to Assembly Manual)
2. Turn all control knobs including sideburner (if featured) to the OFF position.
3. Turn LP tank OFF by turning hand-wheel clockwise to a **full stop**.
4. Remove the protective cap from LP tank valve. Always use cap and strap supplied with valve.

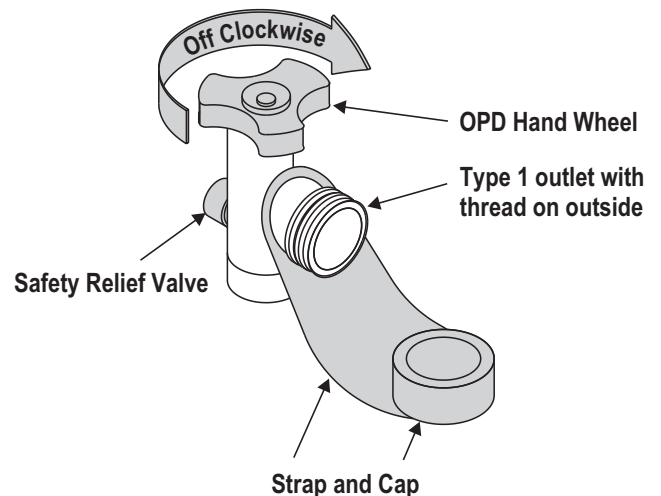

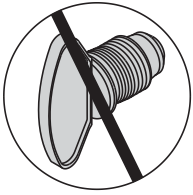

Do not use a POL transport plug (plastic part with external threads)! It will defeat the safety feature of the valve.

5. Hold regulator and insert nipple into LP tank valve. Hand-tighten the coupling nut, holding regulator in a straight line with LP tank valve so as to not cross-thread the connection.

Nipple has to be centered into the LP tank valve.

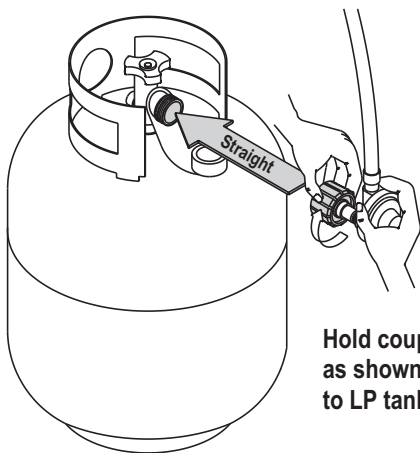
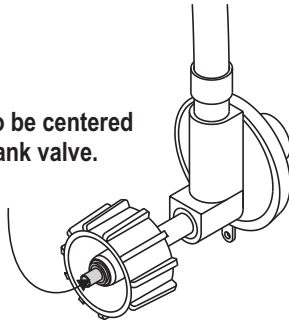

Hold coupling nut and regulator as shown for proper connection to LP tank valve.

6. Turn the coupling nut clockwise and tighten to a full solid stop. The regulator will seal on the back-check feature in the LP tank valve, resulting in some resistance. **An additional one-half to three-quarters turn is required to complete the connection. Tighten by hand only – do not use tools.**

NOTE:

If you cannot complete the connection, disconnect regulator and repeat steps 5 and 6. If you are still unable to complete the connection, **do not use this regulator!**



DANGER



- Do not insert any tool or foreign objects into the valve outlet or safety relief valve. You may damage the valve and cause a leak. Leaking propane may result in explosion, fire, severe personal injury, or death.
- If a leak is detected at any time, STOP and call the fire department.
- If you cannot stop a gas leak, *immediately* close LP tank valve and call LP gas supplier or your fire department!



WARNING



- Never attempt to attach this grill to the self-contained LP gas system of a camper trailer or motor home.
- Do not use grill until leak-tested.

Safety Tips

- ▲ Before opening LP tank valve, check the coupling nut for tightness.
- ▲ When grill is not in use, turn off all control knobs and LP tank valve.
- ▲ Never move grill while in operation or still hot.
- ▲ Use long-handled barbecue utensils and oven mitts to avoid burns and splatters.
- ▲ Maximum load for sideburner and side shelf is 10 lbs.
- ▲ Do not use a cooking pot larger than 9" on the sideburner.
- ▲ A soup can or grease cup **must** be attached to grease clip/grease tray and emptied after each use. Do not remove soup can/grease cup until grill has completely cooled.
- ▲ If you notice grease or other hot material dripping from grill onto valve, hose or regulator, turn off gas supply at once. Determine the cause, correct it, then clean and inspect valve, hose and regulator before continuing. Perform a leak test.
- ▲ The regulator may make a humming or whistling noise during operation. This will not affect safety or use of grill.
- ▲ If you have a grill problem see the "Troubleshooting Section".

Leak Testing Valves, Hose and Regulator

1. Turn all grill control knob(s) to OFF.
2. Be sure regulator is tightly connected to LP tank.
3. Completely open LP tank valve by turning hand wheel counterclockwise. If you hear a *rushing sound*, turn gas off immediately. There is a major leak at the connection. **Correct before proceeding.**
4. Brush soapy solution onto areas where bubbles are shown:

Sideburner Hose
(if featured)

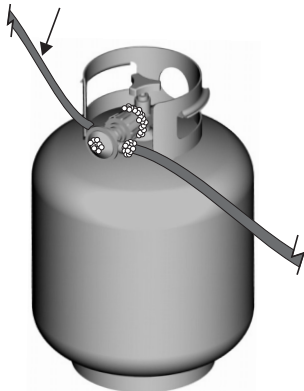

HeatWave Hose
(if featured)

▲ Never remove opening at end of valve.

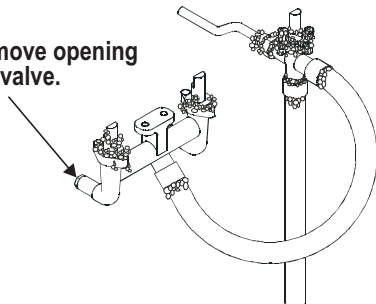

Sideburner Valve



5. If “growing” bubbles appear, there is a leak. Close LP tank valve immediately and re-tighten connections. **If leaks cannot be stopped “do not try to repair”** call for replacement parts. Order new parts by giving the serial number, model number and name of items needed to the Grill Service Center at 1-800-241-7548.
6. Always close LP tank valve after performing leak test by turning hand wheel clockwise.

	<h1>WARNING</h1>	
<ul style="list-style-type: none">• If the regulator frosts turn off grill and LP tank valve immediately. This indicates a problem with the tank and it should not be used on any product. Return to supplier!		

Valve Check

- **Important: Make sure gas is OFF at LP tank before checking valves.** Knobs lock in OFF position. To check valves, first push in knobs and release, knobs should spring back. If knobs do not spring back, replace valve assembly before using grill. Turn knobs to **LOW** position then turn back to **OFF** position. Valves should turn smoothly.

Hose Check

- Before each use, check to see if hoses are cut, worn or kinked. Replace damaged hoses before using grill. Use only valve/hose/regulator specified by manufacturer.



Normal
Hose



Kinked
Hose

Turning Grill Off

- Turn all knobs to **OFF** position. Turn LP tank OFF by turning hand-wheel clockwise to a full stop.

Ignitor Check

- **Turn gas off at LP tank.** Press ignitor button or turn ignitor knob rapidly. "Click" should be heard and spark seen each time between collector box or burner and electrode. See "*Troubleshooting*" if no click or spark.



WARNING



For Safe Use Of Your Grill And To Avoid Serious Injury:

- Do not let children operate or play near grill.
- Keep grill area clear and free from materials that burn.
- Do not block holes in bottom or back of grill.
- Check burner flames regularly.
- Use grill only in well-ventilated space. NEVER use in enclosed space such as carport, garage, porch, covered patio, or under an overhead structure of any kind.
- Do not use charcoal or ceramic briquets in a gas grill. (Unless briquets are supplied with your grill).

- **Use grill at least 3 ft. from any wall or surface.**

Maintain 10 ft. clearance to objects that can catch fire or sources of ignition such as pilot lights on water heaters, live electrical appliances, etc.

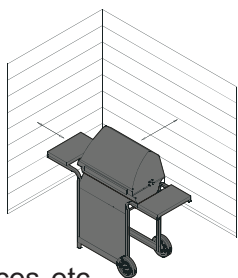

- **Apartment Dwellers:**

Check with management to learn the requirements and fire codes for using an LP gas grill in your apartment complex. If allowed, use outside on the ground floor with a three (3) foot clearance from walls or rails. Do not use on or under balconies.

- **NEVER attempt to light burner with lid closed. A buildup of non-ignited gas inside a closed grill is hazardous.**

- **Never operate grill with LP tank out of correct position specified in assembly instructions.**

- **Always close LP tank valve and remove coupling nut before moving LP tank from specified operation position.**

Ignitor Lighting Traditions Series, QuickSet and QuickSet Traditional

- ▲ **Do not lean over grill while lighting.**

1. **Open lid during lighting.** Turn on gas at LP tank.
2. Turn LEFT knob to 🔥 IGNITE.
3. Push 🔴 Piezo Ignitor Button rapidly, or hold 🔵 Electronic Ignition, or turn 🔵 Rotary Ignitor Knob (up to 5 times) to light. Be sure burner lights and stays lit.
4. If ignition does NOT occur in 5 seconds, turn the burner controls OFF, wait 5 minutes and repeat the lighting procedure.
5. To ignite right burner, turn right knob to 🔥 .
6. If IGNITOR does not work, follow match lighting instructions.

After Lighting: Turn knobs to HI position for warm-up. Do not warm up grill with knobs on IGNITE. Knobs and handle will become uncomfortably hot if left in IGNITE positions.

Match Lighting Traditions Series, QuickSet and QuickSet Traditional

- ▲ **Do not lean over grill while lighting.**

1. **Open lid.** Turn on gas at LP tank.
2. Place lit match into match lighting hole from outside grill bottom (as shown).
3. Push in and turn RIGHT knob to 🔥 IGNITE. Be sure burner lights and stays lit.
4. Light left burner by pushing LEFT knob in and turning to 🔥 IGNITE.

After Lighting: Turn knobs to HI for warm-up.

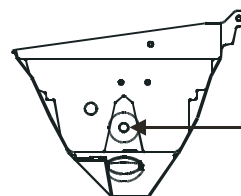
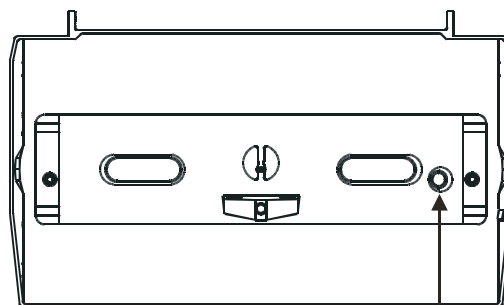

Match-lighting hole is in bottom or side

Ignitor Lighting: Performance and Advantage Series

Two Burner Grill:

- ▲ **Do not lean over grill while lighting.**
- 1. **Open lid.** Turn on gas at LP tank.
- 2. Turn left knob to 🔥.
- 3. Push and hold Electronic Ignitor button.
- 4. If ignition does NOT occur in 5 seconds, turn the burner controls off, wait 5 minutes and repeat the lighting procedure.
- 5. To ignite right burner, turn right knob to 🔥.

Three Burner Grill:

- ▲ **Do not lean over grill while lighting.**
- 1. **Open lid.** Turn on gas at LP tank.
- 2. Turn left knob to 🔥.
- 3. Push and hold Electronic Ignitor button.
- 4. If ignition does NOT occur in 5 seconds, turn the burner controls off, wait 5 minutes and repeat the lighting procedure.
- 5. Ignite center burner by turning center knob to 🔥, then ignite right burner by turning right knob to 🔥.

Four Burner Grill:

- ▲ **Do not lean over grill while lighting.**
- 1. **Open lid.** Turn on gas at LP tank.
- 2. Turn left knob to 🔥.
- 3. Push and hold Electronic Ignitor button.
- 4. If ignition does NOT occur in 5 seconds, turn the burner controls off, wait 5 minutes and repeat the lighting procedure.
- 5. Ignite left-center burner by turning left-center knob to 🔥, then ignite right-center burner by turning right-center knob to 🔥, then ignite right burner by turning right knob to 🔥.

Match Lighting for Two and Three Burner Grills

- ▲ **Do not lean over grill while lighting.**
- 1. **Open lid.** Turn on gas at LP tank.
- 2. *Match holder is on the right rear leg. Attach match to match holder, light match. Place match into match lighting hole from outside of grill bottom (as shown).*
- 3. *Push in and turn right knob to 🔥. Be sure burner lights and stays lit.*
- 4. *Two burner grills, push in and turn left knob to 🔥.*
Three burner grill, push in and turn center knob to 🔥 and then right knob to 🔥.

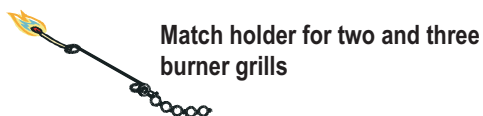

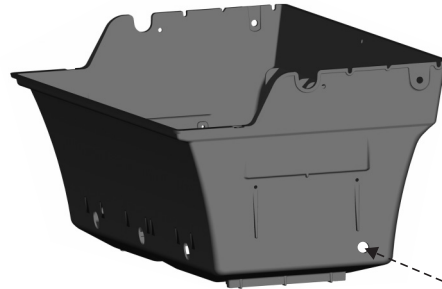

Match Lighting for Four Burner Grills

- ▲ **Do not lean over grill while lighting.**
- 1. **Open lid.** Turn on gas at LP tank.
- 2. *Place lit match into match lighting hole from outside of grill bottom (as shown).*
- 3. *Push in and turn right knob to 🔥. Be sure burner lights and stays lit. Push in right-center burner to light, left center and left burner.*



Match-lighting hole is on side of grill bottom

	<h2>CAUTION</h2>	
<p>If burner does not light, turn knob(s) to OFF, wait 5 minutes, try again. If the burner does not ignite with the valve open, gas will continue to flow out of the burner and could accidentally ignite with risk of injury.</p>		



• Sideburner Use

Do not use a cooking pot larger than 9" on grid.

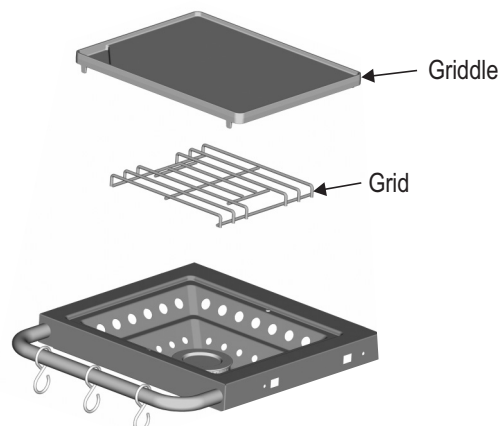
Remove grid from sideburner before using griddle. Never exceed griddle zone value setting shown on graphics. Damage to Teflon® may occur. Do not close lid when using griddle.



Rotisserie Burner Ignitor Lighting

1. Turn all knobs to OFF.
2. **Open lid during lighting.** Turn gas on at LP Tank.
3. Push in and turn Burner Selector Knob to ON ROTISSERIE BURNER.
4. Press  Piezo Ignitor Button or  Electronic Ignition hold up to 5 seconds. Or turn  Rotary Ignitor Knob rapidly (up to 5 times). Be sure burner lights and stays lit.
5. If IGNITOR does not work, follow match lighting instructions above.

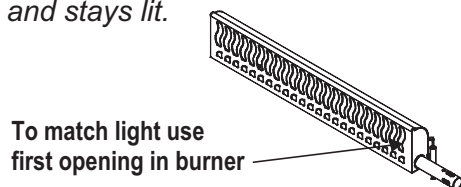

Match Lighting

1. **Open lid.** Turn on gas at LP tank.
2. Place lit match near porthole of burner.
3. Push in and turn Burner Selector Knob to ON ROTISSERIE BURNER. Be sure burner lights and stays lit.



Note: Rotisserie burner and main burner cannot be used at the same time.

Sideburner Ignitor Lighting

1. Turn gas on at LP tank.
2. Push in and turn knob to HIGH.
3. Turn or push    (up to 5 times to light burner). Be sure burner lights and stays lit.
4. If burner does not light turn knob(s) to OFF, wait 5 minutes, try again.

Match Lighting

1. Turn gas on at LP tank.
2. Hold lit match to any port on the burner. Push in and turn sideburner knob to HIGH. Be sure burner lights and stays lit.

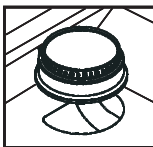

Burner Flame Check

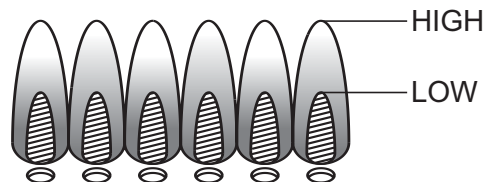

- Light burner, rotate knob(s) from HIGH to LOW. You should see a smaller flame in LOW position than seen on HIGH. Always check flame prior to each use. Perform flame check on sideburner (if equipped). If only low flame is seen refer to "Sudden drop or low flame" in the *Troubleshooting Section*.



Rotisserie burner only has one setting so flame cannot be checked.

Before Your First Cookout

- Light burners, check to make sure they are lit, close the lid and warm up grill on HI for 15 minutes. Curing of paint and parts will produce an odor only on first lighting.

	CAUTION	
<ul style="list-style-type: none">• Putting out grease fires by closing the lid is not possible. Grills are well ventilated for safety reasons.• Do not use water on a grease fire. Personal injury may result. If a grease fire develops, turn knobs and LP tank off.• Do not leave grill unattended while preheating or burning off food residue on HI. If grill has not been regularly cleaned, a grease fire can occur that may damage the product.		

Cleaning The Traditional Series, QuickSet and QuickSet Traditional Burner Assembly

Follow these instructions to clean and/or replace parts of burner assembly or if you have trouble igniting the grill.

1. **Turn gas off at control knobs and LP tank.**
2. Remove cooking grate and V-Bar.
3. Under grill remove soup can, (unscrew ignitor button and remove battery on electronic ignition models), disconnect short ignitor wire (A) and clips from burner (B). To remove clips pull down on large end of clip attached to the valve, turn away from valve, rotate upward and remove small end of clip from burner tube.
4. Inside grill remove burner assembly (C), clean ceramic portion of electrode with rubbing alcohol and a swab.
5. Clean outside of burner with soap and water. Lay burner upside down on flat surface, insert garden hose to force water through tubes. Make sure water comes out of all burner holes. Open clogged holes with a thin wire. Shake out excess water and examine holes. Due to normal wear and corrosion some holes may become enlarged. If any large cracks or holes are found replace burner.
6. If grill is to be stored, coat burner lightly with cooking oil. Wrap in protective cover to keep insects out.
7. If not storing grill after cleaning, replace burner into grill bottom (C).
8. To reattach clips hold large curved end away from burner tube, insert small curved end into hole under burner tubes, turn clip towards valve, snap into place.

VERY IMPORTANT: Clips must be attached correctly for proper grill function (B).

9. Reattach ignitor wire to ignitor (A). (Reinstall battery and ignitor button on electronic ignition models.)
10. Reposition v-bar and cooking grate(s). Reattach clean can to grease clip.
11. Before cooking again on grill, perform a *“Leak Test”* and *“Burner Flame Check”*.

▲ Do not use ceramic briquets or charcoal unless a charcoal pan comes with your grill.

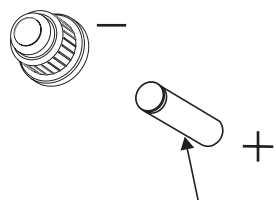
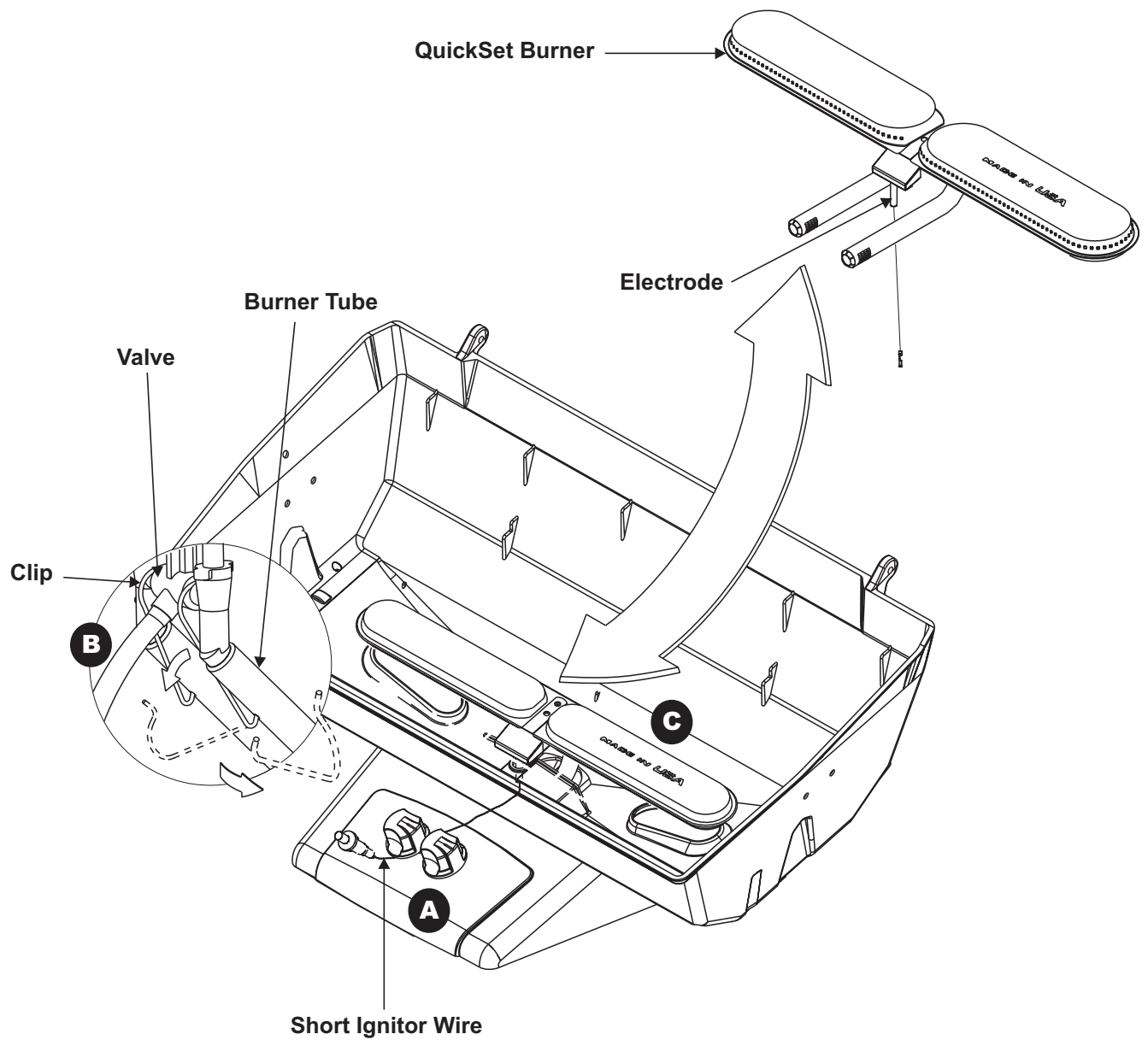

Remove button and battery on electronic ignition models

Cleaning The Performance and Advantage Burner Assembly

Follow these instructions to clean and/or replace parts of burner assembly or if you have trouble igniting the grill.

1. **Turn gas off at control knobs and LP tank.**
2. Remove cooking grids and vaporizer tents.
3. Remove two pal nuts, carry-over tube and burners.
4. Under grill remove grease pan and tray. Clean with soap and water.
5. Disconnect battery and under console disengage ignitor wire.
6. Wipe ceramic electrode with rubbing alcohol and cloth.
7. Clean carry-over tube and burners exterior with soap and water. Lay burners on flat surface, insert garden hose (preferably with nozzle), into burner tubes forcing water through tubes. Make sure water comes out of every porthole. Open clogged portholes with a thin wire. **Shake out excess water** and examine porthole. Due to normal wear and corrosion some portholes may become enlarged, if so replace burner. If any horizontal cracks appear from porthole to porthole or large holes (other than portholes) are found replace burner.
8. If grill is to be stored, coat burners lightly with cooking oil. Wrap in protective cover to keep insects out. If not storing use following steps.

VERY IMPORTANT: Burner tubes must engage valve openings as shown (A).

9. Attach ignitor wire to electrode. *Replace battery.*
10. Reposition cooking grids and vaporizer tents. Place clean grease tray and pan into grill bottom.
11. Before cooking again on grill, perform a “*Leak Test*” and “*Burner Flame Check*”.

▲ Do not use ceramic briquets or charcoal in your grill.

Cleaning the Performance and Advantage Grease Tray

Performance and Advantage Series grills are equipped with a removable grease tray. Although grease will drain from the grease tray to the grease cup provided, food particles and debris may accumulate in the bottom and should be removed after cooking 5 to 10 times. This can easily be done by sliding the grease tray out of the rear of the unit. Make sure in replacing the tray to push it all the way forward.



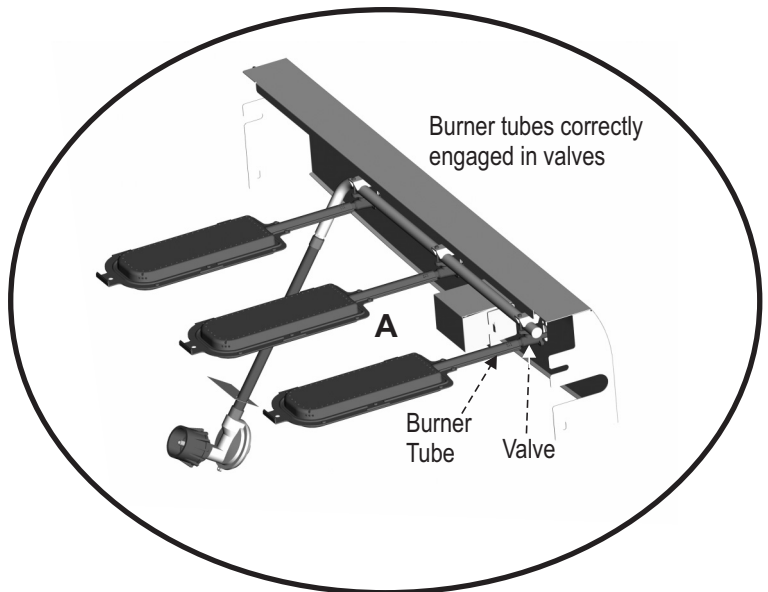
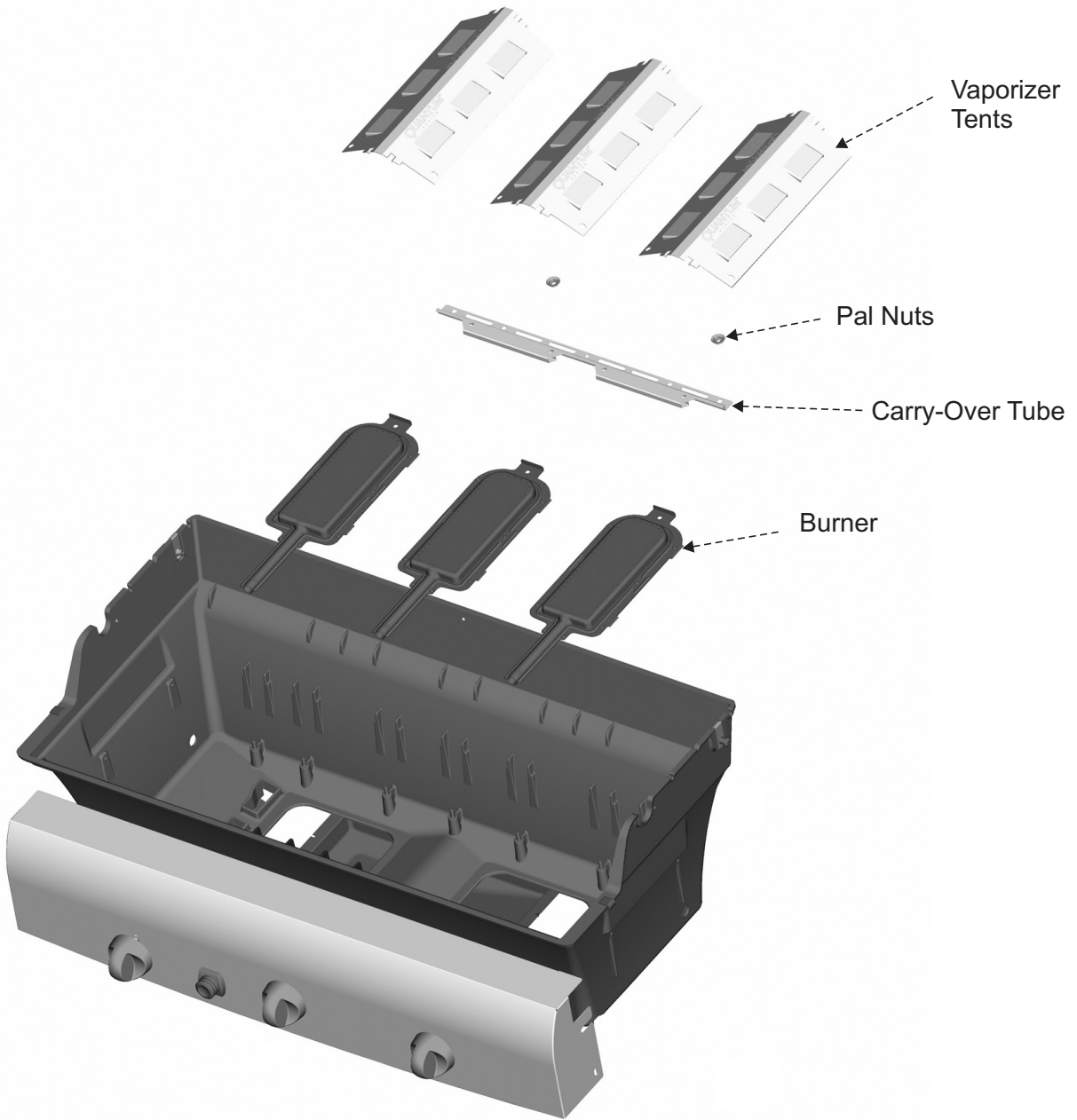

Cleaning The Rotisserie Burner

Follow these instructions to clean and/or replace parts of burner assembly or if you have trouble igniting the grill.

1. **Turn gas off at control knobs and LP tank.**
2. Disconnect ignitor wire from electrode (A).
3. Remove thumbscrew from shield (B), remove shield and clean any accumulation of grease with soap and water.
4. Unfasten hinge pins and hitch pin. Note how hinge pins and hitch pins are attached.
5. Using a garden hose (preferably with nozzle), force water through burner tube. Make sure water comes out of every burner porthole. Open clogged portholes with a thin wire.
6. Examine rotisserie housing and burner closely (C). If any cracks or large holes (other than portholes) are found replace rotisserie burner.
7. Wipe ceramic portion of electrode (A) with rubbing alcohol and cloth.
8. If grill is to be stored, coat burners lightly with cooking oil. Wrap in protective cover to keep insects out. If not storing use following steps.
9. After burner has been cleaned, place rotisserie burner onto back of grill bottom and attach with hinge pins and hitch pins.
10. Place gas tube inside burner tube, put shield over burner tube and secure with thumbscrew.

VERY IMPORTANT: Burner tubes must engage gas tube as shown (D).

11. Attach flat end of ignitor wire (A) to electrode.

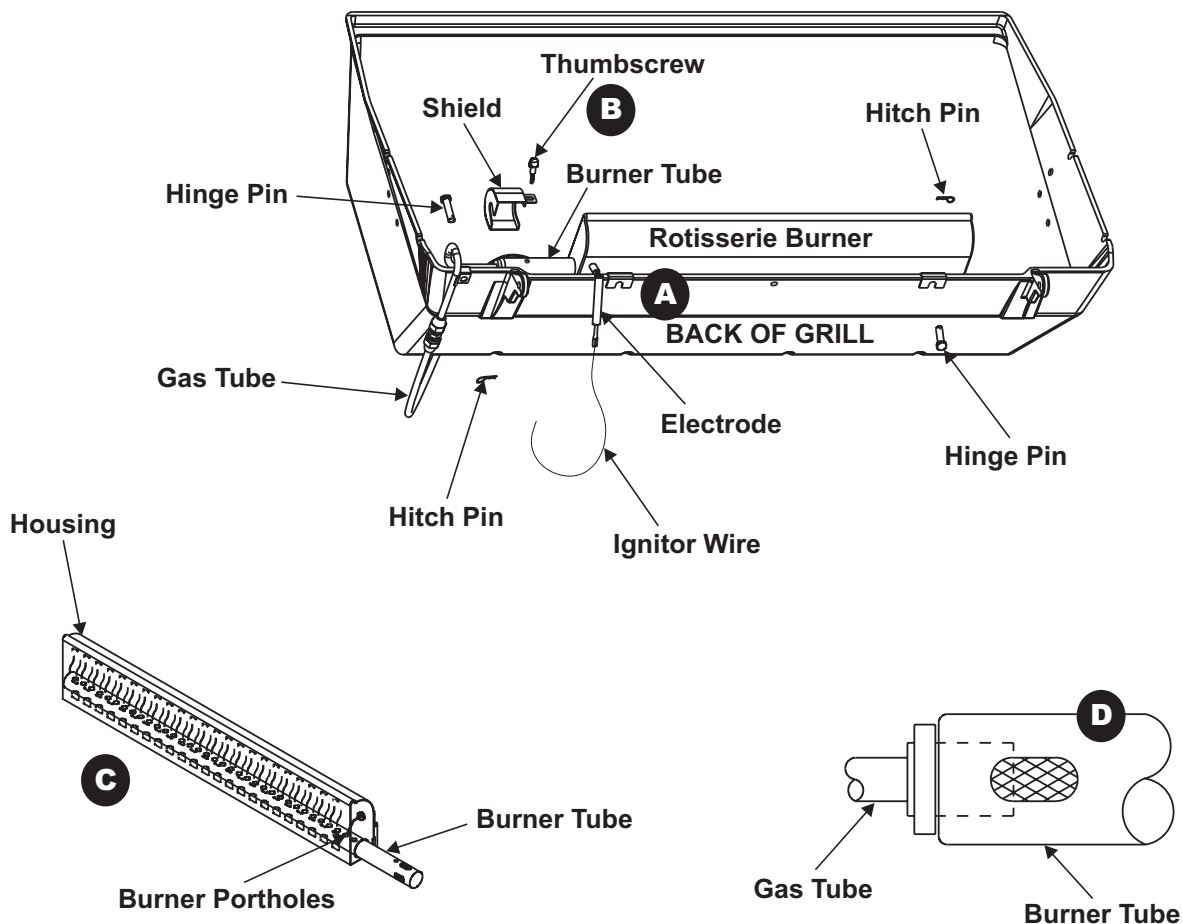

Rotisserie Burner Use

The rotisserie burner is a 10,500 BTU radiant heat burner that transforms your grill into a multilevel cooking center. It is attached to the back of the bottom casting, above the main grid.

You can use the burner as a broiler to cook foods on the cooking grates or bonus-grid. If you do, then you cannot use the bottom burner.

Or, you can remove the cooking grates or bonus grid, install a rotisserie and use the burner to perfectly roast foods on the split. This is the most common use for the burner. You cannot use the bottom burner with this process either.

By not using the lower burner, the grease and food drippings won't burn and cause flare-ups. It's healthier, it's fuel-efficient, and it creates a delicious slow-cooked roast beef, chicken, or veggie kabob on the rotisserie...or a beautiful broiled salmon, lobster, or vegetable medley on the grill.

Cooking Chart For Rotisserie Burner

Item	Weight	Time	Tips
Chicken/Fryer	3.5 lbs.	65 minutes	Internal temperature 180°F
Turkey Breast/ Bone-in	2.5 lbs.	1 hr: 30 min.	Internal temperature 170°F
Cornish Hens	20 oz.	1 hr: 10 min.	Internal temperature 180°F
Duck	4.5lbs.	2 hr: 15 min.	Internal temperature 180°F
Pork Shoulder	3.25 lbs.	2 hr: 45 min.	Place pan of water in bottom of grill. Internal temperature 170°F.
Pork Boston Butt Roast	3.3 lbs.	2 hr: 45 min.	Place pan of water in bottom of grill. Internal temperature 170°F.
Pork Tenderloin	1.25 lbs.	Med: 40 min. Well: 50 min.	Internal temperature: Med: 160°F Well: 170°F
Pork Spareribs/ Beef Back Ribs	2.75 lbs.	1 hr: 30 min.	Place pan of water in bottom of grill.
Beef Bottom Round Roast	3.3 lbs.	Med rare: 1 hr 50 min. Med: 2 hrs. Well: 2 hrs: 10 min.	Internal temperature: Med rare: 140°F Med: 150°F Well: 160°F

Cooking Tips

- If you set a foil pan in the bottom casting, right on the burner, it will catch any food drippings created by cooking with the Rotisserie Burner. You'll have no grease in the grill to clean.
- If you group different vegetables by the length of time it takes to cook, then everything will be done at the same time. Check the enclosed food chart for cooking times.

General Grill Cleaning

- Keep the outside of your grill looking new by cleaning it once a month with warm soap and water or a non-abrasive cleaner. If you don't have a grill cover, wipe off dust and grime before starting your grill.
- Coating the cooking grids with spray-on cooking oil will keep the food from sticking and make clean up easier. After cooking, scrape the grates with a long handled, brass wire bristle brush.
- Check inside the grill bottom for grease build-up and clean often, especially after cooking fatty meat.
- Do not mistake brown or black accumulation of grease and smoke for paint. Interiors of gas grills are not painted at the factory (**and should never be painted**). Apply a strong solution of detergent and water or use a grill cleaner with scrub brush on insides of grill lid and bottom. Rinse and allow to completely air dry. **Do not apply a caustic grill/oven cleaner to painted surfaces.**
- **Vaporizer Tents:** Will eventually decompose and weaken with use. Remove from grill and tap to loosen any scaling. Brush vigorously with a wire brush to remove any additional scaling, rust or residue.
- **Plated wire grate(s):** Wash grate(s) and V- bar with concentrated grill cleaner or use soap and water solution. Dry thoroughly and store indoors between cookouts.
- **Plastic parts:** Wash with warm soapy water and wipe dry. ▲ Do not use citrisol, abrasive cleaners, degreasers or a concentrated grill cleaner on plastic parts. Damage to and failure of parts can result.
- **Porcelain grate(s):** Because of glass-like composition, most residue can be wiped away with baking soda/water solution or specially formulated cleaner. Use non-abrasive scouring powder for stubborn stains.

Repainting Your Grill

- After extended use and exposure to weather, paint on grill may change color slightly or become spotted. Although this detracts from grill's appearance, it will not impair its performance.
- To refinish your grill brush outside of grill lid and bottom with wire brush and lightly sand with fine grit sandpaper. Sanding allows new paint to adhere more easily. Wash grill lid and bottom with soap and water to remove dust and grease. Do not use a grill cleaner on outside of grill. Wipe with vinegar. Refinish outside with heat-resistant paint. Do not paint inside of grill.

Care And Cleaning Of Stainless Steel

Routine cleaning is necessary to preserve the appearance and corrosion resistance of Stainless Steel. The methods below are suggestions for cleaning stainless steel surfaces. Choose a cleaning method appropriate to the requirement. If you choose to use scouring powder or solvents, consult with the solvent manufacturer or supplier before use.

Before cleaning, first test any cleaning product in an inconspicuous location and consider the possibility of scratching and the potential for corrosion caused by not completely removing cleaners. Never use brushes or steel wool as they will scratch and leave particles embedded on stainless steel surfaces, which can lead to rusting. Always rub or wipe in the direction of the polish lines in the stainless steel surface, not across them. Thorough rinsing with clean water is recommended after all cleaning procedures. Dry all surfaces completely after rinsing. Be careful not to let any stainless steel cleaner come in contact with painted or plastic components as damage may occur.

Routine Care

The Char-Broil® Stainless Steel Grill Cleaner and the Thermos® Stainless Steel Grill Cleaner are good choices for routine cleaning of stainless steel surfaces. Mild stains and loose dirt and soil can also be removed with a soft cloth and clean warm water. Rinse with clean water and wipe dry.

Stubborn Stains

Stubborn stains, discoloration and possibly rust and rust pitting can occur from cooking, exposure to harsh outdoor conditions, or extreme cooking temperatures. There are many cleaning agents commercially available formulated to restore the finish of stainless steel. Obtain advice from the solvent manufacturer or supplier when choosing the appropriate cleaner for your requirement. These cleaners can be acidic. Care should be taken to avoid contact with eyes or mouth. Be careful not let any powder or solvent come in contact with painted or plastic components as damage may occur.

The chart below has been reproduced with permission from the Specialty Steel Institute of North America. For additional details regarding the care and cleaning of stainless steel, visit their website at www.ssina.com for more information. For the latest new products for the care and cleaning of stainless steel go to www.charbroil.com.

Job	Cleaning Agents*	Comments
Routine Cleaning	Warm Water, Soap, Ammonia, Detergent	Apply with sponge or soft cloth. Can be used on all finishes.
Fingerprints and Smears	3M Stainless Steel Cleaner and Polish, Arcal 20, Lac-O-Nu, Lumin Wash, O'Cedar Cream Polish, Stainless Shine	Provides barrier film to minimize fingerprints. Can be used on all finishes.
Stubborn Stains and Discoloration	3M Stainless Steel Cleaner and Polish, All chem Concentrated Cleaner, Samae, Twinkle, Cameo Copper Cleaner, Grade FFF or Grade F Italian Pumice, Whiting or Talc, Liquid Nu Steel, Copper's or Revere Stainless Steel Cleaner, Household Cleaners, Lumin Cleaner, Zud Restoro, Sta-Clean, Highlite, Allen Polish, Penny-Brite, Copper-Brite	Rub lightly, using dry damp cloth, in the direction of polish lines on the stainless steel.
Grease and Blood Burnt-on or Baked-on Foods	Scotch-Brite Power Pad 2001, Easy-Off, De-Grease-It, 4% to 6% hot solution of such agents as tri-sodium polyphosphate, 5% to 15% caustic soda solution	Excellent removal on acids, all finishes. Particularly useful where rubbing is not practical.
Grease and Oil	Any good commercial detergent or caustic cleanser.	Apply with sponge or soft cloth in direction of polish lines.

*NOTE: Use of proprietary names is intended only to indicate a type of cleaner and does not constitute an endorsement. Omission of any proprietary cleanser does not imply its inadequacy. All products should be used in strict accordance with instructions on package.

 **CAUTION** 

NATURAL HAZARD • SPIDERS

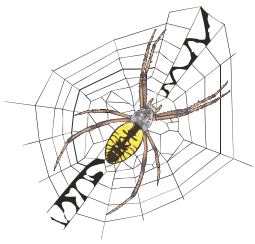

FACT: Sometimes spiders and other small insects climb into the burner tubes attached to the burner. The spiders spin webs, build nests and lay eggs. The webs or nests can be very small, but they are very strong and can block the flow of gas. Clean burner(s) prior to use after storing, at the beginning of grilling season or after a period of one month not being used.

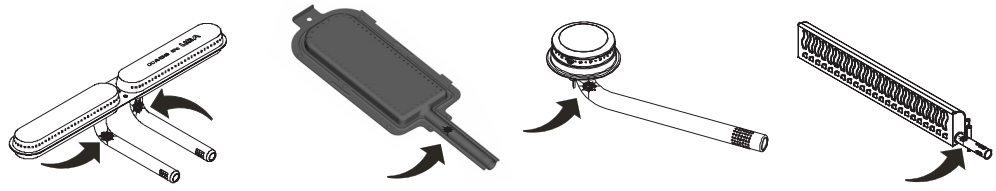

Typical spider webs inside burner

Spider Guards are on the air intakes in an effort to reduce this problem, but it will not eliminate it! An obstruction can result in a “flashback” (a fire in the burner tubes). The grill may still light, but the obstruction does not allow full gas flow to the burner(s).

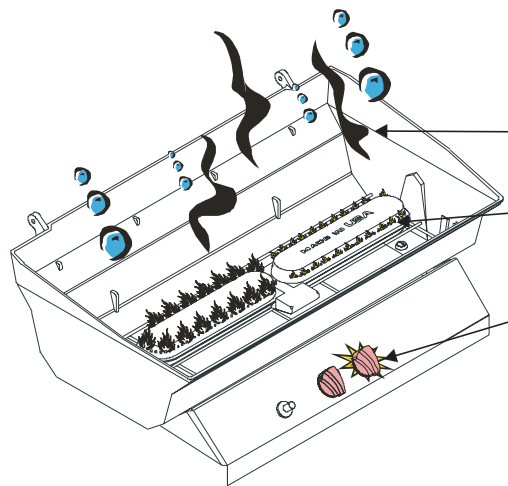

IF YOU EXPERIENCE THE FOLLOWING:

- 1. Smell gas.
- 2. Burner(s) will not light.
- 3. A small yellow flame from burner (should be blue).
- 4. Fire coming from around or behind a control knob.

STOP!
Immediately turn off gas at LP tank.

▲ After a venturi fire you must inspect the hose and do a “Leak Test” to assure no damage has occurred to the parts.

SOLUTION: Wait for grill to cool.

Follow the cleaning instructions for your appropriate grill. Clean burners often. Spiders and insects don’t care if your grill is brand new or you just cleaned it. We have found in trying to remove web’s from the burner tubes a 12” pipe cleaner cleans out the tubes, or water from a hose with a nozzle attached. Forced water is needed to wash out the web.

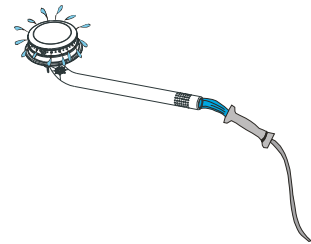

Charcoal/Gas Grills

If you haven't attached the handles to the grate follow step 1.

Step 1. Left handle is shown in the correct position between second and third wire from end. Hook end of right handle over back and pull to hook over front wire.

- Remove cooking grate(s) and hang on back of grill using the hanger wire.
- Remove V-bar and place two pan supports into grill bottom.
- Remove warming rack from leg wire and straight wire.
- Rotate leg wire toward back of grill bottom.
- Place charcoal tray on pan supports.
- Rotate grate support wires in the tray into upright positions.
- Fill charcoal tray with one layer of charcoal briquettes.
- Place warming rack in the upper position on the wire grate supports.

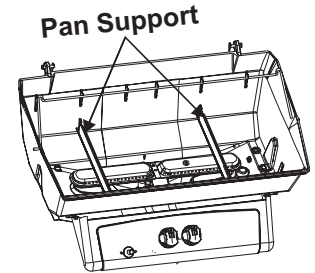
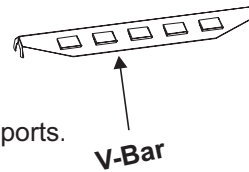
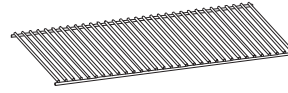
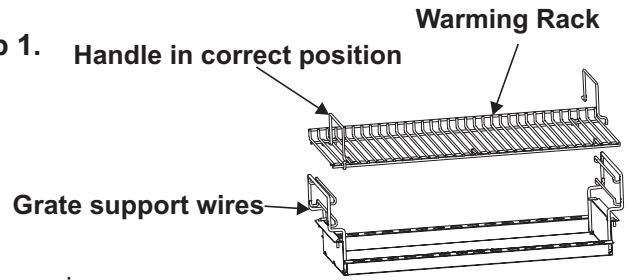

▲ Use oven mitts during cooking.

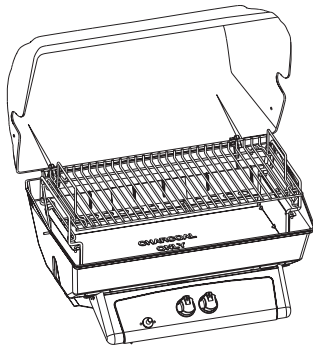

Grill Series: 7000 & 8000 QuickSet Traditional

- Follow standard lighting instructions to light the grill.
- Turn both control knobs to "HI" position.
- Close lid and wait 10 minutes.
- Open lid and continue to heat for 5 to 10 minutes.
- Turn control knobs to "OFF" position.
- Let charcoal briquettes continue to whiten for 10 to 15 minutes.



WARNING



- ▲ Make sure ashes are cool and there are no hot embers prior to storing your grill. Do not store grill until coals are cold.
- ▲ Use only enough charcoal to cover the bottom of the pan.
Grill Series 7000: 4 briquets wide by 10 long
Grill Series 8000: 5 briquets wide by 12 long
- ▲ Always light grill using gas. Never use lighter fluid, kerosene, gasoline or alcohol.
- ▲ Burning charcoal produces carbon monoxide, a toxic odorless fume. Carbon monoxide accumulation may cause illness and/or death.

Cooking Chart

Cooking times and temperatures may vary according to specific recipes, cooking conditions or barbecue equipment used. Take these factors into consideration to insure best results. If you use the indirect cooking method (indirect cooking is lighting only one burner and placing food on opposite side of cooking grate), allow more grilling time.

Temperatures: High = 650°F / Medium = 450°F / Low = 300°F.

Food	Setting	Cooking Time
Beef Hamburger 1/2" thick	Medium	Med: 7-10 min. / Well done: 10-15 min.
Steak 1/2"	Medium-Hot	Rare: 3-6 min. / Med: 6-9 min. / Well done: 9-12 min.
Roast	Low	Rare: 18-22min. per lb. / Med: 22-28 min. per lb. / Well done: 28-32 min. per lb.
Pork Chops 1/2"	Medium	Well done: 15-20 min.
Ribs 5-6 lbs.	Low-Medium	Well done: 45-90 min.
Roast 3-5 lbs.	Low-Medium	Well done: 18-23 min. per lb.
Ham Steak 1/2"	Medium-Hot	12-15 min.
Ham 5 lb. fully cooked	Low-Medium	20 min. per lb.
Lamb Chops 1/2"	Medium	6-12 min.
Poultry Chicken 2-1/2 to 3-1/2 lbs.	Low	1 hr., 15 min. to 1 hr., 30 min.
Chicken halved or quartered	Low	40-60 min.
Turkey	Low-Medium	18-20 min. per lb.
Seafood Steaks 1" thick	Medium-Hot	Well done: 10-25 min.
Filletts 6-8 oz.	Medium-Hot	8-12 min.
Shrimp large or jumbo	Low-Medium	8-12 min.
Venison Steak 1" thick	Medium	Rare: 8-10 min. / Med: 10-12 min.
Burgers 1/2"	Medium	Rare: 10-12 min. / Med: 12-15 min.
Roast 3-4 lbs.	Low-Medium	Rare: 20-22 min. per lb. / Med: 22-25 min. per lb.
Vegetables Baking Potato whole	Low	<i>Wrap vegetables in foil</i> 55-60 min.
Onions whole	Low	45 min.
Tomatoes half	Medium	30-40 min.
Corn whole	Low	35-45 min.
Mushrooms	Medium	15-20 min.

Food Safety

- Food safety is a very important part of enjoying the outdoor cooking experience. To keep food safe from harmful bacteria, follow these four basic steps:

Clean: Wash hands, utensils and surfaces with hot soapy water before and after handling raw meat and poultry.

Separate: Separate raw meats and poultry from ready-to-eat foods to avoid cross contamination. Use a clean platter and utensils when removing cooked foods.

Cook: Cook meat and poultry thoroughly to kill bacteria. Use a thermometer to ensure proper internal food temperatures.

Chill: Refrigerate prepared foods and leftovers promptly.

For more information call: USDA Meat and Poultry Hotline at 1-800-535-4555 in Washington, DC (202) 720-3333, 10:00 am-4:00 pm EST

How To Tell If Meat Is Grilled Thoroughly

- Meat and poultry cooked on a grill often browns very fast on the outside. Use a meat thermometer to be sure food has reached a safe internal temperature, and cut into food to check for visual signs of doneness.
- Whole poultry should reach 180°F; breasts 170°F. Juices should run clear and flesh should not be pink.
- Hamburgers made of any ground meat or poultry should reach 160°F, and be brown in the middle with no pink juices. Beef, veal and lamb steaks, roasts and chops can be cooked to 145°F. All cuts of pork should reach 160°F.
- NEVER partially grill meat or poultry and finish cooking later. Cook food completely to destroy harmful bacteria.
- When reheating takeout foods or fully cooked meats like hot dogs, grill to 165°F, or until steaming hot.

Storing Your Grill

- Clean cooking grate(s) and discard old briquets.
- Store in dry location.
- When LP tank is connected to grill, store outdoors in well-ventilated space and out of reach of children.
- Cover grill if stored outdoors. Choose from a variety of grill covers offered by Char-Broil.
- Store grill indoors ONLY if LP tank is turned off and disconnected, removed from grill and stored outdoors.
- When removing grill from storage follow *"Cleaning Burner Assembly"* instructions before starting grill.

Troubleshooting

Emergencies	Possible Cause	Prevention/Solution
Gas leaking from cracked/cut/burned hose.	<ul style="list-style-type: none"> • Old hose, cut in hose. 	<ul style="list-style-type: none"> • Turn off gas at LP tank or at source on natural gas systems. If hose is cut or cracked, replace valve/hose/regulator. If burned, discontinue use of product until a gas service technician/plumber has investigated cause and correction is made.
Gas leaking from LP tank.	<ul style="list-style-type: none"> • Mechanical failure due to rusting or mishandling. 	<ul style="list-style-type: none"> • Turn off LP tank valve.
Gas leaking from LP tank valve.	<ul style="list-style-type: none"> • Failure of tank valve from mishandling or mechanical failure. 	<ul style="list-style-type: none"> • Call LP gas dealer 800-number on tank label or call local fire department.
Gas leaking between LP tank and regulator connection.	<ul style="list-style-type: none"> • Improper installation, connection not tight, failure of rubber seal. 	<ul style="list-style-type: none"> • Remove regulator from tank and visually inspect rubber seal for damage. Reinstall and check for leaks. Ensure black knob is on tight.
Fire coming through control panel.	<ul style="list-style-type: none"> • Fire in burner tube section of burner due to partial blockage. • Misalignment of valve to burner tube. 	<ul style="list-style-type: none"> • Turn off LP tank valve (if possible without injury to self). If fire cannot be controlled with baking soda/extinguisher, call local fire department. Remove burner and inspect for spider nest or rust. Clean using bottle brush. • Ensure valves and burner tubes are aligned per assembly instructions.
Grease fire or continuous excessive flames above cooking surface.	<ul style="list-style-type: none"> • Too much grease buildup in burner area. 	<ul style="list-style-type: none"> • Turn off LP tank valve. Leave lid open to allow flames to die down. After cooling, clean food particles and excess grease from inside firebox area, grease cup/pan/tray, and other surfaces.
Problem	Possible Cause	Prevention/Solution
<p>Burner(s) will not light using ignitor. (See Electronic Ignition Troubleshooting also)</p> <p><i>Continued on next page.</i></p>	<p>GAS ISSUES:</p> <ul style="list-style-type: none"> • Trying to light wrong burner. • Burner not engaged with control valve. • Obstruction in burner. • No gas flow. • Vapor lock at coupling nut to LP tank. • Coupling nut and LP tank valve not fully connected. <p>ELECTRICAL ISSUES:</p> <ul style="list-style-type: none"> • Electrode cracked or broken; "sparks at crack." • Electrode tip not in proper position. • Wire and/or electrode covered with cooking residue. • Wires are loose or disconnected. • Wires are shorting (sparking) between ignitor and electrode. • Dead battery. 	<ul style="list-style-type: none"> • See instructions on control panel and in Use and Care manual. • Make sure valves are positioned inside of burner tubes with clips attached (if featured). • Ensure burner tubes are not obstructed with spider webs or other matter. See cleaning section of Use and Care manual. • Make sure LP tank is not empty. If LP tank is not empty, refer to "Sudden drop in gas flow." • Turn off knobs and disconnect coupling nut from LP tank. Reconnect and retry. • Turn the coupling nut approximately one-half to three-quarters additional turn until solid stop. Tighten by hand only - do not use tools. • Replace electrode(s). <p>Main Burners Traditional Series, QuickSet and QuickSet Series:</p> <ul style="list-style-type: none"> • Tip of electrode should be pointing toward tip of collector box . The distance should be 1/8" to 1/4". Adjust if necessary. <p>Main Burners Performance and Advantage Series:</p> <ul style="list-style-type: none"> • Tip of electrode should be pointing toward port hole in burner. The distance should be 1/8" to 3/16". Adjust if necessary. <p>Sideburner:</p> <ul style="list-style-type: none"> • Tip of electrode should be pointing toward gas port opening on burner. The distance should be 1/8" to 3/16". Adjust if necessary. • Clean wire and/or electrode with rubbing alcohol and clean swab. • Reconnect wires or replace electrode/wire assembly. • Replace ignitor wire. • Replace with a new AAA-size alkaline battery.

Troubleshooting (continued)

Problem	Possible Cause	Prevention/Solution
Burner(s) will not light using ignitor. (See Electronic Ignition Troubleshooting also)	<p>ELECTRONIC IGNITION:</p> <ul style="list-style-type: none"> • No spark, no ignition noise. • No spark, some ignition noise. • Sparks, but not at electrode or at full strength. <p>PIEZO PUSH-BUTTON AND ROTARY:</p> <ul style="list-style-type: none"> • Push-button sticks at bottom. • Rotary knob rotates without clicking. • Sparking between ignitor and electrode. 	<ul style="list-style-type: none"> • See Section I of Electronic Ignition System. • See Section II of Electronic Ignition System. • See Section III of Electronic Ignition System. • Replace ignitor. • Replace knob. • Inspect wire insulation and proper connection. Replace wires if insulation is broken.
Burner(s) will not match light.	<ul style="list-style-type: none"> • See “GAS ISSUES:” on previous page. • Match will not reach. • Improper method of match-lighting. 	<ul style="list-style-type: none"> • Use paper match, long-stem match (fireplace match) or match holder (where supplied). • See “Match-Lighting” section of Use and Care manual.
Sudden drop in gas flow or low flame.	<ul style="list-style-type: none"> • Out of gas. • Excess flow valve tripped. • Vapor lock at coupling nut/LP tank connection. 	<ul style="list-style-type: none"> • Check for gas in LP tank. • Turn off knobs, wait 30 seconds and light grill. If flames are still low, turn off knobs and LP tank valve. Disconnect regulator. Reconnect regulator and leak-test. Turn on LP tank valve, wait 30 seconds and then light grill. • Turn off knobs and LP tank valve. Disconnect coupling nut from tank. Reconnect and retry.
Flames blow out.	<ul style="list-style-type: none"> • High or gusting winds. • Low on LP gas. • Excess flow valve tripped. 	<ul style="list-style-type: none"> • Turn front of grill to face wind or increase flame height. • Refill LP tank. • Refer to “Sudden drop in gas flow” above.
Flare-up.	<ul style="list-style-type: none"> • Grease buildup. • Excessive fat in meat. • Excessive cooking temperature. 	<ul style="list-style-type: none"> • Clean burners and inside of grill/firebox. • Trim fat from meat before grilling. • Adjust (lower) temperature accordingly.
Persistent grease fire.	<ul style="list-style-type: none"> • Grease trapped by food buildup around burner system. 	<ul style="list-style-type: none"> • Turn knobs to OFF. Turn gas off at LP tank. Leave lid in position and let fire burn out. After grill cools, remove and clean all parts.
Flashback... (fire in burner tube(s)).	<ul style="list-style-type: none"> • Burner and/or burner tubes are blocked. 	<ul style="list-style-type: none"> • Turn knobs to OFF. Clean burner and/or burner tubes. See burner cleaning section of Use and Care manual.
Unable to fill LP tank.	<ul style="list-style-type: none"> • Some dealers have older fill nozzles with worn threads. 	<ul style="list-style-type: none"> • The worn nozzles don’t have enough “bite” to engage the valve. Try a second LP dealer.
One burner does not light from other burner(s).	<ul style="list-style-type: none"> • Grease buildup or food particles in end(s) of carryover tube(s). 	<ul style="list-style-type: none"> • Clean carry-over tube(s) with wire brush.

Troubleshooting - Electronic Ignition

Problem (Ignition)	Possible Cause	Check Procedure	Prevention/Solution
<p>SECTION I No sparks appear at any electrodes when ignition button is pushed; no noise can be heard from spark module.</p>	<ul style="list-style-type: none"> • Battery not installed properly. • Dead battery. • Button assembly not installed properly. • Faulty spark module. 	<ul style="list-style-type: none"> • Check battery orientation. • Has battery been used previously? • Check to ensure button assembly is fully engaged. Button should travel up and down without binding. • If no sparks are generated with new battery and good wire connections, module is faulty. 	<ul style="list-style-type: none"> • Install battery (make sure that “-” and “+” connectors are oriented correctly, with “-” end up and “+” end down.) • Replace battery with new AAA-size alkaline battery. • Remove button cap assembly and reinstall, making sure it can be fully engaged. • Replace spark module assembly.
<p>SECTION II No sparks appear at any electrodes when ignition switch is pushed; noise can be heard from spark module.</p>	<ul style="list-style-type: none"> • Output lead connections not connected. • Electrode tip not in proper position. 	<ul style="list-style-type: none"> • Are output connections on and tight? • Are the electrode tips pointing in the right direction? Is the gap too big? 	<ul style="list-style-type: none"> • Remove and reconnect all output connections at module and electrodes. <p>Main Burners: Traditional Series, QuickSet or QuickSet Traditional: • Tip of electrode should be pointing toward tip of collector box. The distance should be 1/8” to 1/4”. Adjust if necessary. Performance and Advantage Series: • Tip of electrode should be pointing toward port hole in burner. The distance should be 1/8” to 3/16”. Adjust if necessary. Sideburner: • Tip of electrode should be pointing toward gas port opening on burner. The distance should be 1/8” to 3/16”. Adjust if necessary.</p>
<p>SECTION III Sparks are present but not at all electrodes and/or not at full strength</p>	<ul style="list-style-type: none"> • Output lead connections not connected. • Arcing to grill away from burner(s). • Weak battery. • Electrodes are wet. • Electrodes cracked or broken “sparks at crack”. 	<ul style="list-style-type: none"> • Are output connections on and tight? • If possible, observe grill in dark location. Operate ignition system and look for arcing between output wires and grill frame. • All sparks present but weak or at slow rate. • Has moisture accumulated on electrode and/or in burner ports? • Inspect electrodes for cracks. 	<ul style="list-style-type: none"> • Remove and reconnect all output connections at module and electrodes. • If sparks are observed other than from burner(s), wire insulation may be damaged. Replace wires. • Replace battery with a new AAA-size alkaline battery. • Use paper towel to remove moisture. • Replace cracked or broken electrodes.

Recipes by Chef Christopher Koetke, CEC, CCE

Five-Spice Grilled Duck Breast with Asian BBQ Sauce

Serves 4

4 boneless skinless duck breasts	1 garlic clove, minced
2 teas. finely grated orange zest	1-1/2 teas. five spice mix
1-1/2 teas. salt	1/4 teas. black pepper

Combine garlic, orange zest, five spice, salt and pepper with duck breasts. Let marinate in refrigerator for 4-24 hours. Grill duck breasts over high heat. Turn the breasts and liberally brush Asian BBQ sauce on top. Grill until breasts are 150-155° internal temperature. While breast are cooking, grill green onions over high heat until they begin to soften (about 2 minutes). Serve with duck breasts. Additional Asian BBQ sauce (perhaps thinned with a little water) can be served on the side.

Asian BBQ Sauce

Serves 3-4

2 Tbles. oyster sauce	6 Tbles. hoisin sauce
1/4 teas. Tabasco	2 Tbles. orange juice
1 teas. sesame oil	

Mix ingredients together until blended. Store covered in refrigerator until needed.

Ratatouille Melts

Serves 3-4

2 zucchini, diced (about 3 cups)	1 medium eggplant, diced (about 4 cups)
1 large red pepper, diced (about 1-1/2 cups)	1 large onion, finely diced (about 1-1/2 cups)
4 garlic cloves, minced	4 large tomatoes, seeded and diced
1/2 to 3/4 cup extra virgin olive oil	1-1/2 teas. salt
1/2 teas. black pepper	1/3 cup Parmesan cheese
2 cups grated Mozzarella cheese	1/2 cup chopped fresh basil
1 foot long French bread	

In a large sauté pan, sauté zucchini over high heat in 2 Tbles. olive oil. Cook until zucchini are lightly browned and softened. Set aside in a bowl. Sauté eggplant over high heat in 3-4 Tbles. olive oil until lightly browned and softened. Add to bowl. In the same sauté pan, sauté red pepper over moderate heat in 2 Tbles. olive oil. Cook until red peppers are lightly browned and softened. Add to bowl. Sauté onions in 3 Tbles. olive oil until translucent, add garlic, cook 2 more minutes. Add zucchini, eggplant and red pepper. Reduce heat and cook 15 minutes, or until all ingredients are very soft. Season with salt and pepper. (At this point, ratatouille can be chilled and reheated when necessary). Cut bread in half lengthwise. Scoop out center of bread so that it looks like a boat. Fill bread with hot ratatouille. Sprinkle with Basil, Parmesan and Mozzarella. Place filled breads over low heat. Cover grill and cook until cheese is melted and bread is toasted.

Char-Broil Turkey

Yield: 14 to 16 generous servings or 1 lb. per person

Cooking time: 25 minutes per pound • Method: Grill on low

12 to 14 lb. turkey, thawed completely	vegetable oil
1 large apple, quartered	1 quart water
1-1/2 sticks butter	2 stalks celery, cut in 2" pieces
1 orange, quartered	2 onions, cut in large cubes
1 lemon, thinly sliced or 4 tbs. lemon juice	salt and pepper
cheesecloth (optional)	

Heat grill to medium. Wash and rinse turkey, removing giblets. Dry with absorbent paper. Bend wings back behind turkey. Season inside of turkey with salt and pepper. Rub outside of bird with oil. Stuff with onions, celery, orange and apple. Completely fill cavity (this gives moisture to the turkey). Cover openings of turkey with excess skin. Melt butter in a large aluminum foil pan. Add turkey, water and lemon juice. Place on grill and turn heat to low. Baste with butter, cover top with cheesecloth and baste again. Baste every 1/2 hour until done. Serve with Giblet Gravy.

Giblet Gravy

2 to 3 turkey or chicken giblets	salt and pepper to taste
3-4 lbs. turkey or chicken fat	1/4 teas. Accent
1/4 cup flour	dash of thyme
2 cups fat-free pan juices	1/8 teas. Kitchen Bouquet
2 hard boiled eggs, finely chopped	milk, if needed
giblet broth, if needed	

Boil giblets until tender, reserving broth. Chop giblets and set aside. Remove grilled turkey from baking pan and place on hot platter. Pour all pan juices into large measuring cup. Skim off fat, reserving 3 to 4 Tbles. Place reserved fat into a deep saucepan, heating over moderate heat. Stir in flour, whisking well with wire whisk. Cook over low heat until bubbly then remove from heat. Add fat free pan juices (add milk and giblet broth to juices to make 2 full cups). Blend well with wire whisk. Season with salt, pepper, Accent, thyme and Kitchen Bouquet, whisking continuously. Return mixture to heat and continue stirring for 3 to 4 minutes. Add chopped eggs.

Smoked Turkey Breast

Cooking time: 25 minutes per pound • Method: Grill indirect heat

1 turkey breast, fresh or thawed	1 large bottle Italian dressing
1 large plastic roasting bag	1 small bottle soy sauce

Mix dressing and soy sauce. Place turkey breast in bag and pour mixture over turkey breast. Marinate in refrigerator overnight. Light one side of grill with setting on low. Remove turkey from marinade and reserve liquid. Put meat thermometer in turkey breast being certain not to touch bone. Place turkey on the grill away from direct heat. Grill over low fire, basting and rotating often. Remove when meat thermometer registers 180°F.

Please register your grill online at:

WWW.GRILLREGISTRATION.COM

(If you register online, you do not need to send in this registration card.)

PLEASE FILL OUT THIS CARD AND RETURN IT *WITHIN 10 DAYS OF PURCHASE. FAILURE TO RETURN MAY AFFECT YOUR WARRANTY COVERAGE.*
 LLENE ESTA TARJETA Y DEVUÉLVALA DENTRO DE LOS 10 DÍAS DE LA COMPRA. *SI NO LA DEVUELVE, PUEDE VERSE AFECTADA SU COBERTURA DE GARANTÍA.*
 VEUILLEZ COMPLÉTER CETTE CARTE ET LA RETOURNER DANS LES 10 JOURS SUIVANT L'ACHAT.
 LA COUVERTURE DE VOTRE GARANTIE POURRAIT EN ÊTRE AFFECTÉE SI VOUS NE LE FAITES PAS.

1 First Name/Nombre/Prénom _____ Initial/Inicial/Initiale _____ Last Name/Apellido/Nom de famille _____
 Address (number and street)/Dirección (número y calle)/Adresse (numéro et rue) _____ Apt Number/Nº de apart./Nº d'appt. _____
 City/Ciudad/Ville _____ State/Estado/Province _____ Zip Code/Código zip/Code postal _____

2 E-mail Address/Dirección de correo electrónico/Adresse électronique _____
If you voluntarily provide us with your email address, you give us permission to use your email address to send you offers that may interest you.
Si nos informa voluntariamente su dirección de correo electrónico, nos da permiso para usarlo a fin de enviarle ofertas que pueden interesarle.
Si vous choisissez de nous fournir votre adresse électronique, vous nous donnez la permission de l'utiliser pour vous faire part d'offres spéciales susceptibles de vous intéresser.

(Example: your name@your host.com) (Ejemplo: su nombre@su host.com) (Exemple : votre nom@votre hôte.com)

3 Phone Number/Número telefónico/Numéro de téléphone _____

6 Date of Purchase/Fecha de compra/Date de l'achat _____

4 **IMPORTANT!/IMPORTANTE!/IMPORTANT!**
 Write Serial Number and Model Number in spaces below.
 Escriba en los espacios de abajo el número de serie y el número de modelo.
 Inscrivez le numéro de série et le numéro de modèle dans les espaces ci-dessous.

7 Store Name/Nombre de la tienda/Nom du magasin _____

8 Purchase Price/Precio de compra/Prix d'achat
 \$ _____ .00

5 Your Gender/Su sexo/Sexe: 1. Male/Masculino/Masculin 2. Female/Femenino/Féminin

- 9** Which product are your registering?
 ¿Qué producto está registrando?
 Quel produit enregistrez-vous?
- 1. Gas Grill/Parrilla de gas/ Gril au gaz
 - 2. Electric Grill/Parrilla eléctrica/ Gril électrique
 - 3. Smoker/Ahumadora/Fumoir
 - 4. Charcoal Grill/Parrilla de carbón/ Barbecue au charbon
 - 5. Charcoal Smoker/Ahumadora de carbón/Fumoir au charbon
 - 6. Outdoor Fireplace/Hogar para exteriores/Foyer extérieur
 - 7. Cooker/Fryer / Cocina/freidora / Cuisneur/Friteuse
 - 8. Other/Otro/Autre

- 10** Which of these sources influenced your decision to buy this product? (check all that apply)
 ¿Cuál de estas fuentes influyó a su decisión de comprar este producto? (Marque todas las que correspondan)
 Parmi les éléments ci-dessous, qu'est-ce qui a influencé votre décision d'acheter ce produit? (Cochez tous les éléments s'appliquant)
- 1. Magazine/newspaper advertisement / Propaganda en revista/periódico / Publicité dans un magazine ou dans un journal
 - 2. Television commercial/Comercial televisivo/Publicité à la télévision
 - 3. Grill was assembled/Parrilla ensamblada/Le gril était déjà assemblé
 - 4. In-store display/Exhibidor en la tienda/Promotion sur le lieu de vente
 - 5. Store circular/Circular de la tienda/Prospectus de magasin
 - 6. Brand name/Marca/Marque
 - 7. Product style/Estilo del producto/Style du produit
 - 8. Price/value / Precio/valor / Rapport prix/valeur
 - 9. Product quality/Calidad del producto/Qualité du produit
 - 10. Friend/Relative recommendation / Recomendación de amigo o pariente / Recommandation d'un(e) ami(e)/parent(e)
 - 11. Salesperson recommendation/Recomendación del vendedor/ Recommandation d'un(e) préposé(e) à la vente
 - 12. Grill size/Tamaño de la parrilla/Taille du gril
 - 13. Product warranty/Garantía del producto/Garantie du produit
 - 14. Store demonstration/Demostración en la tienda/Démonstration en magasin
 - 15. Point of purchase/Punto de compra/Lieu de vente
 - 16. Other/Otras/Autre: _____

Mail to:
Product Registration Dept.
PO BOX 1240
Columbus, Georgia 31902-1240

Thank you for completing this questionnaire. Your answers will help us and other companies reach you with offers that may interest you. If you prefer not to receive these offers, please check here .

Gracias por completar este cuestionario. Sus respuestas nos ayudarán, a nosotros y a otras compañías, a llegar a ustedes con ofertas que puedan resultarles de interés. Si prefiere no recibir estas ofertas, por favor marque aquí .

Merci d'avoir bien voulu remplir ce questionnaire. Vos réponses nous aideront et aideront d'autres compagnies à vous communiquer des offres spéciales susceptibles de vous intéresser. Si vous préférez ne pas recevoir d'informations concernant ces offres spéciales, veuillez cocher ici .

Certified Grill Parts And Accessories®, Char-Broil and Design®, Char-Broil (Gas Grill Briquettes)®, Char-Diamonds®, Cooking Zone and Design®, Diamond Flame®, Executive Chef®, Faststart®, Flare Fighter®, FlavorMaster®, Gas Grill Silhouette and Design®, H2O Smoker®, Lava Flame®, MasterFlame®, MasterFlame Precision Cooking System®, PowerSpark®, Quantum®, PrecisionFlame and Design®, Sierra® and TruFlame® are registered Trademarks of the W.C. Bradley Company. Thermos® is a registered trademark of the Thermos Company and its affiliates.

Artisan Collection by Char-Broil™, C3 and Design™, Char-Broil and Design™, Flame Design™, FlavorTents™, Grill 2 Go™, Grillin' Stick™, Keeper of the Flame™, Keepers of the Flame™, Natural Grip™, Outdoor Cooking Collection and Design™, Patio Bistro™, PrecisionFlame™, Pro-Check™, QuickSet Grills and Design™, SmokerTents™, The Big East™, The Minute Grill™, The Edge™, The Tuscan Collection™, and The Urban Grill™ are Trademarks of the W.C. Bradley Company. Universal Grill Parts and Design™ is a trademark of the Thermos Company and its affiliates.

Protected under one or more of the following U.S. Patents: 4,598,692; 4,624,240; 4,747,391; 4,747,391; 4,817,583; 4,924,846; 4,989,579; 5,003,960; 5,076,256; 5,076,257; 5,090,398; 5,109,834; 5,224,676; 5,277,106; 5,421,319; 5,441,226; 5,452,707; 5,458,309; 5,566,606; 5,579,755; 5,582,094; 5,613,486; 5,649,475; 5,706,797; 5,711,663; 5,765,543; 5,931,149; 5,996,573; 6,095,132; 6,135,104; 6,173,644; 6,279,566; 6,397,731; 6,418,923; 6,439,222; 6,523,461; 6,792,936; D282,619; D339,714; D341,292; D343,337; D358,059; D361,466; D364,535; D372,637; D373,701; D377,735; D383,035; D397,910; D405,643; D405,643; D406,005; D406,009; D413,043; D413,229; D413,229; D414,982; D415,388; D416,164; D416,441; D417,587; D422,516; D423,274; D423,876; D428,303; D435,396; D463,004; D438,059; D438,060; D438,427; D439,110; D442,505; D443,179; D443,354; D447,384; D447,385; D447,909; D448,610; D448,614; D448,615; D448,616; D448,975; D449,492; D451,759; D456,202S; D460,313; D461,359 and D477,501. Canada: 87743; 87744; 92607; 92608 and 1,316,424. Other Patents Pending. ©2004 W.C. Bradley Co., All Rights Reserved.

ARRÊTEZ

En cas de problème
CONTACTEZ NOUS D'ABORD.
e ramenez pas ce produit au magasin.
NOUS POUVONS VOUS AIDER.

1-800-387-6057

24 heures sur 24 - 7 jours sur 7

SERVICE APRÈS-VENTE DU GRILL

Recette pour grillade en toute sécurité

- Lisez tous les manuels d'utilisation
- Remplissez la carte de garantie
- Assurez-vous que les valves sont correctement installées sur les tuyaux des brûleurs
- Assurez-vous que les boutons de commande sont en position OFF
- Remplissez le réservoir PL, le cas échéant
- Effectuez un essai d'étanchéité

Merci de votre achat

STOP

Should you encounter any problem

CALL US FIRST

Do not return this product to the store.

WE CAN HELP

1-800-241-7548

24 Hours a Day - 7 Days a week

GRILL SERVICE CENTER

Recipe for Grilling Safely

- Read all Owner's Manuals
- Complete Warranty Card
- Ensure valves are correctly installed in burner tubes
- Ensure control knobs lock on OFF position
- Fill LP Tank, if provided
- Perform Leak Test

Thank You for Your Purchase!